

Adiabatic Blanking of metal sheets: Technological positioning and industrial developments for production

Dr. Lazzarotto, L. and Dipl.-Ing. Michon, R.

ADIAPRESS. 53, rue Scheurer Kestner. F-42 000 Saint Etienne. France.

Abstract

The savings (materials, consumables, production and financial costs) that the new technology of adiabatic blanking enables compared to the conventional blanking technologies are possible thanks to the process itself but also because of the industrial developments made by ADIAPRESS regarding the tooling and machinery. It is also shown that thin tubes adiabatic cutting of tubes is possible. The main concepts and developments are discussed in this paper.

1 Introduction

High quality of components, costs reduction and mass production due to standardization strategy in automotive industry and other sectors are the main market demands. Sheet metal forming processes are able to reach these requirements. Up to now, two processes were available: conventional blanking and fine blanking. When the sheared face of the component has no functional use, the conventional blanking process is adapted. In the other cases, the fine blanking process is required to warrant the roughness, geometry, etc. of the sheared faces. Fine blanking process needs complex tools and machines working at low production rates. Moreover this process needs a lot of lubricants and materials with globulisation softening heat treatments. No fundamental innovation has been developed in the sheet metal blanking field within the 50 previous years. The adiabatic blanking process, developed by ADIAPRESS during the 5 previous years,

is the only alternative technology that enables to obtain a high quality level (close to fine blanking) at lower cost (close to conventional stamping). Moreover, it is also expected that due to the adiabatic phenomenon, the blanking field can be enlarged for instance to blank thicker parts or harder materials.

This paper first explains the main savings induced by the adiabatic blanking process on an industrial point of view. Then, the principles and phenomena that govern the process are detailed. Part of the developments made by ADIAPRESS during the last 5 years is presented.

2 Savings

The adiabatic blanking process is a completely new and cost efficient way to produce blanked parts with a functional surface. Based on the experience with a prototype line ADIAPRESS has done a wide range of parts. It appeared that the savings regarding the conventional blanking techniques are important.

Material saving of at least 8 % thanks to the new strip organization that the technology enables. As the plastic strain area is limited, the material between two parts can be strongly reduced. Moreover it has been shown with cold rolled materials that the pull in depth is reduced. Thus, for a same functional thickness of the blanked face, the thickness of the metal sheet can be reduced. This is an extra and powerful way to save materials. Moreover, there is no need of globalization pre-heat treatments due to the self overheating generated by the adiabatic process.

A production rate increase of 50% compared with fine blanking only due to the potential of the rammer unit and the concept of the tooling (no counter force, no v-ring, etc). For the same reasons, the **tooling costs** can be reduced by **25%** compared to the fine blanking.

Consumables saving of 100%. Indeed, the adiabatic blanking process is a lubricant free process. This also induces that there is no need of degreasers and any degreasing machines.

Other financial and production cost savings can be achieved because there is no, or only few burrs, on the parts. Thus the de-burring processes can be

suppressed or shortened. To conclude, the industrial production flow will be simplified.

3 Adiabatic blanking process

3.1 Principles

The “adiabatic phenomenon” is generated by a high velocity impact that produces a localized plastic strain within the impacted material. The result is a strong temperature increase, close to the melting temperature, in a very short time (100 μ s) and in a limited area (100 μ m) [1]. Thus, the material softens and the produced heat has no time to exchange with its environment (tooling, strip, part) before shearing. As the material softens, the plastic strain increases again. Thus, an extra temperature rise is obtained and so on. This is the autocatalytic cycle (Fig. 1) that produces adiabatic shear bands able to split soft and hard materials. This phenomenon can be industrially used for bars or profiles cutting but also for blanking.

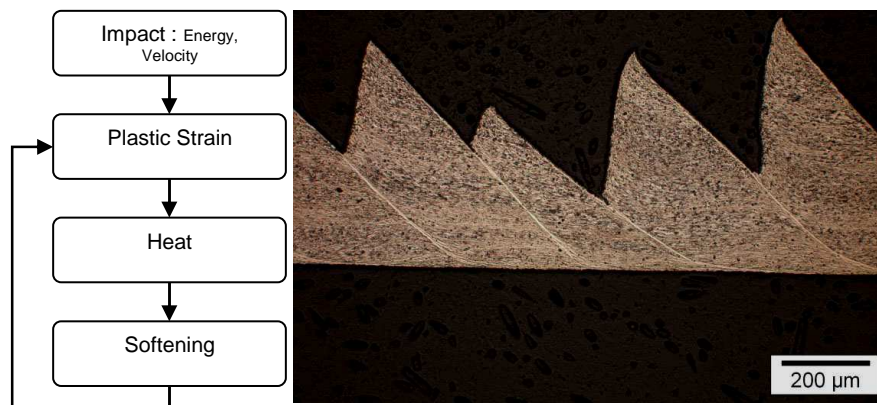

Figure 1: Principle of development of adiabatic shear bands and micrograph of an example of adiabatic shear band produced by High Velocity Machining [1].

As for high speed machining, which is working with the same adiabatic shearing mode, no lubricant is needed in adiabatic cutting or blanking.

The sheared face in such conditions has a high quality level in terms of roughness and geometry. Moreover, due to the localization of the plastic strain in the vicinity of the sheared face and to the potential case hardening of the surface involved by the process itself, the adiabatic blanking process offers a completely new field of savings and applications for sheet metal working.

For blanking, the machine hits the punch that produces an adiabatic shear band all around its shape and through the sheet thickness. As the part is strongly accelerated by the punch impact, its own inertia force contributes to the blanking process. We observed that the part is ejected before than the punch reaches the upper plane of the die. As a consequence, in adiabatic cutting the stroke of the punch will be limited to the thickness of the metal sheet to blank (Fig. 2). This is a major advantage if it is needed to work with very small clearances or if there is some seizure or sticking risks when the punch has to penetrate the die cavity.

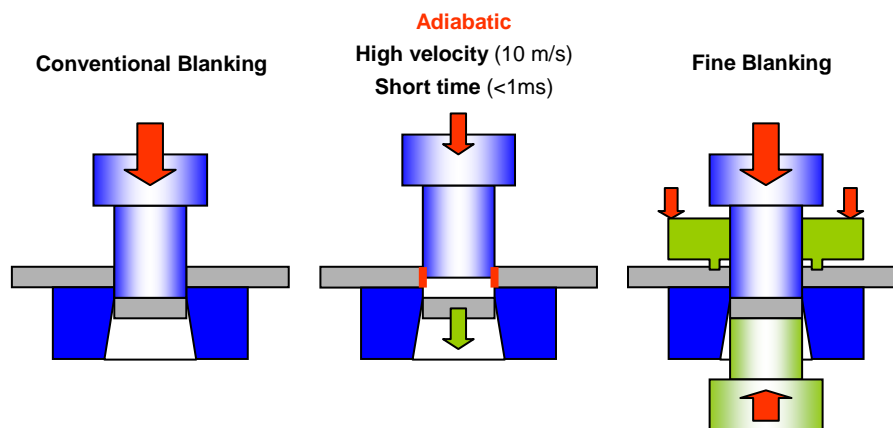

Figure 2: Adiabatic blanking principle.

3.2 Technological results and positioning

Main technological and part quality advantages: Previous research and development works [2] have demonstrated the feasibility and the interest of the adiabatic blanking process:

- The strain hardened area is limited to the vicinity of the blanked surface,
- Burrs are very small and in many cases no burrs are observed,
- No cracks appear along the blanked surface,
- Both the roughness ($R_a = 0,6 - 1,5 \mu\text{m}$; $R_z = 9 - 18 \mu\text{m}$) and the geometry of the blanked surface are close to the quality levels obtained by fine blanking,

As the deformation of the blanked edges is lower than the deformation obtained in conventional or fine blanking and because of the quality level of the blanked face, the adiabatic process is able to produce functional surfaces in cost efficient conditions (Fig. 3).

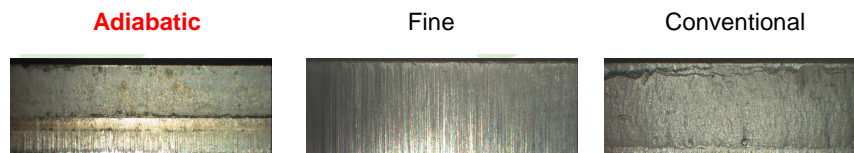

Figure 3: Blanked surfaces of steel part (4 mm thick): adiabatic, fine and conventional blanking [2].

Materials: The different parts that have been tested and developed by ADIAPRESS (Fig. 4) for customers have demonstrated that the adiabatic process can be used for a wide range of material. Copper, aluminum, titanium and steels parts have been blanked with good results. We observed that quite similar smooth blanked surfaces can be obtained with different materials in the same tooling. This indicates that the results are not very sensitive to the value of the die-punch clearance when the thickness is close. We conclude from our experiments that the dimensions of the parts are more governed by the dimensions of the punch than the ones of the die. The important parameter that needs to be adjusted when the material is changing is the blanking energy. Indeed, the mechanical characteristics of the sheet material and also its thermal properties are very important for the development of

the adiabatic phenomenon. Low thermal conductivity materials will be good candidates for adiabatic shear bands occurrence and development.



Figure 4: Example of blanked parts from different materials and shapes.

Thickness: First of all, we observed that the adiabatic blanking process is a very efficient process to blank thick and very thick materials. Most of the industrial blanked parts for structural applications and gears are in the range 4-6 mm (Fig. 4). Nevertheless many other applications for automotive industry and others need thicker parts, i.e. cams for camshafts, masses for crankshafts, pawls, etc. The latest developments made together with Fraunhofer Institute IWU demonstrate the possibility to blank complex shapes with 10 mm thick steel plates (Fig. 5 a) with low deformation compared to the conventional processes [3]. Such a result also indicates that the adiabatic process is a way to increase the potential of the blanking market. An other development with IWU consists in the adiabatic cutting of thin tubes (Fig. 5b). In this purpose, Adiapress has developed an adapted tool that can be fitted on the same machine as the blanking tools. As figure 5b shows, a high quality level of the sheared face with no burrs and a very limited deformation of the edge and of the circular section is obtained with both steel and aluminum tubes.

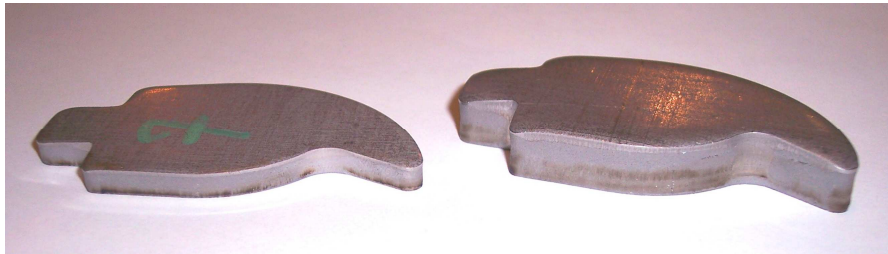

Figure 5a: Example of steel blanked parts: thicknesses 5 and 10 mm..



Figure 5b: Cutted steel tube (diameter 60 mm, thickness 2 mm).

4 Machinery and tooling's developments

The high velocity ($\sim 10 \text{ m.s}^{-1}$) and the quite small stroke length – close to the thickness magnitude (4 to 6 mm) – required by the adiabatic blanking process generate very high acceleration and deceleration values ($10,000 - 100,000 \text{ m.s}^{-2}$). Such acceleration levels will generate important forces that have to be considered in the design of machines and tooling's; a mass of one kg generates a force of 10 – 100 kN. The design has also to take into account the kinetic energy of the mobile parts and also potential rebounds and vibrations. Also in this field some compromises have to be done because in one hand, lightening is the goal and in the other hand, mass is required for choc absorption.

4.1 Tooling

The acceleration forces and kinetic energy discussed above are also applied to the blanked part. In this case the acceleration force contributes to the blanking process because it “pulls” the part out of the die. In practical, we can observe that the parts are really suddenly ejected through the die (Fig 2). We measured some parts velocities of 7 m.s^{-1} for 10 ms^{-1} impact velocities.

Three main tool concepts for blanking have been developed and tested by ADIAPRESS.

A first concept has been developed for rather small parts with small blanking step (Fig. 6a). Here the punch insures both the guiding function needed for the die alignment and the active blanking edges. ADIAPRESS has also developed and patented a way to fit punches as inserts on the main punch nose.

A second tool concept is more adapted to small blanking shapes regarding the dimension of the part (Fig. 6b). In this approach the punches are the smaller as

possible and a guiding plate insure the die alignment. A striking plate hits the punches simultaneously. In an other approach several smaller striking units (see chapter 4.2 Machinery) could be used to hit each punch separately.

A third tool concept, that has been recently developed by ADIAPRESS is especially well adapted for medium to large parts (Fig. 6c). This very innovative design insures both high quality guidance and thus a very good die alignment and a wide possibility of punch organisation thanks to light mobile set. Part of it is made from a casted aluminium frame reinforced by steel inserts. This latest tool concept also allows several parts to be blanked at each strike to increase the production rate and to optimise the material consumption.

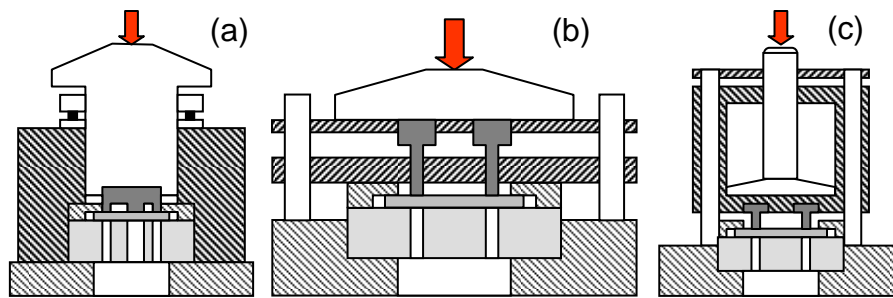

Figure 6: Tool concept for small parts (a), localized blanking (b), and large and/or complex part (c).

ADIAPRESS focuses its developments on the concepts 1 and 3 because they are able to cover a large range of part shapes.

Materials and treatments: ADIAPRESS punches are made of tool steels from powder metallurgy with very high microstructure cleanliness to insure the best compromise between impact strength and hardness. More conventional tool steels can be used for dies. To reduce wearing and seizure effects some thin PVD coatings are recommended with pre and post controlled polishing operations.

Shock absorption: Some absorbers are integrated within machine and the tool in order to have some high velocities during the blanking process itself and to stop the punches before they reach the upper face of the dies.

Adiabatic cutting of tubes and profiles: The adiabatic cutting process for bars and profiles is already available at the industrial level since several years. In 2008, ADIAPRESS has developed and patented a new tool concept for tube or hollow profiles cutting (Fig. 7).

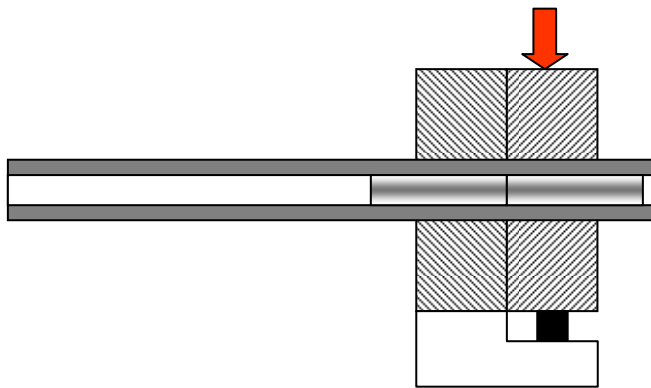

Figure 7: Basic principle of the tube cutting process.

4.2 Machinery

ADIAPRESS' machine and especially the ADIA 7 (7 kJ) has been designed to simplify the role of the operator during production changing and starting cycles, production itself, maintenance, etc. and to make safe and convenient the working conditions.

Principle of the High Velocity Machines and control of the energy: The machines developed to generate the adiabatic shear bands can be assimilated to hammers used in the forging industry but with higher velocities ($> 10 \text{ m.s}^{-1}$) and lighter impacting masses. The frame consists in a massive table and stiff legs to

absorb the impacts and avoid vibrations. Adiapress uses hydraulics rammer units from Hydroplusor because they are reliable and easy to adjust. The impacting mass can be assimilated to a hydraulic piston of a cylinder. It is accelerated thanks to a sudden and constant oil flow from accumulators. Thus, the velocity of the piston is a function of the acceleration stroke of the piston before it hits the tooling (upper punch). So, to control the energy level, the machine controls this stroke length (Fig. 8). For industrial use the operator just has to indicate the reference of the part, material, thickness and the contour length. The machine calculates the needed energy and adjusts automatically the stroke length.

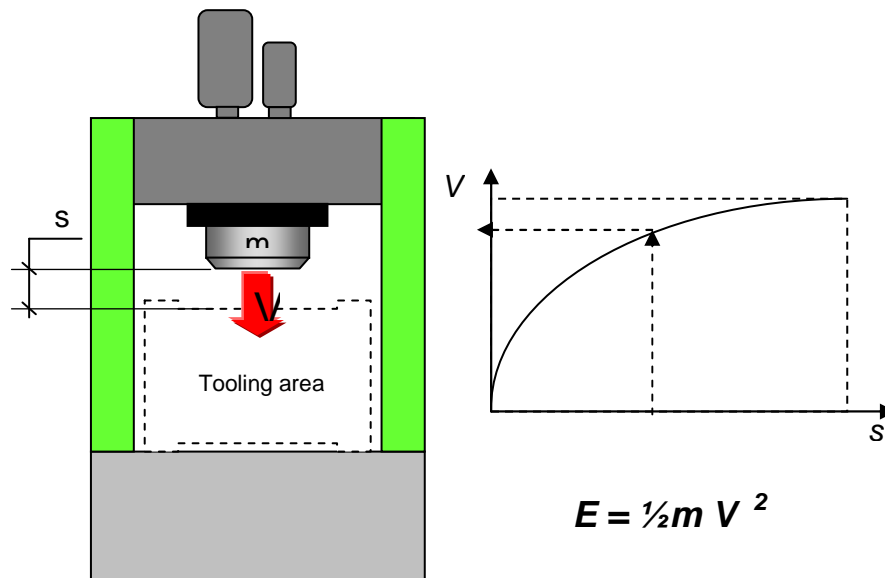

Figure 8: Principle of ADIPRESS' machines and control of the energy.

Performances: The ADIA 7 series machine has been developed by ADIAPRESS to answer to the largest range of the blanking market that is mainly focussed on medium parts of 4-6 mm thickness. ADIA 7 can deliver adjustable impacts up to 7,000 J with a frequency of 5 strikes per second. Such an energy level makes possible to blank the parts usually made with a 350 tons conventional press. In continuous production, the production rate depends of the performances of the

peripheral equipments (uncoiler, straightener, feeder). The complete production line can reach 120 strikes per minute depending on the selected peripheral equipments. Of course several parts can be blanked at each strike. The production rate also depends on the dimensions of the metal sheet. ADIA 7 enables steel sheets of 200 mm width and 8 mm thick to be blanked. The high production rates those are reachable with adiabatic blanking lines imply an efficient production organisation. To help the user to go further in this way ADIAPRESS has designed the machine so that the tooling can be changed in 2 minutes. An innovative maintenance system has also been developed and is installed as series equipment on the ADIAPRESS' machines. This video-tele-maintenance system enables the user to be in connection with the specialists of ADIAPRESS in a few minutes. Both of them can speak, show and see what happens in real time thanks to a camera, screens and a secured internet connection. With such a system, a large part of troubleshooting can be achieved in a very short time and at very low costs.

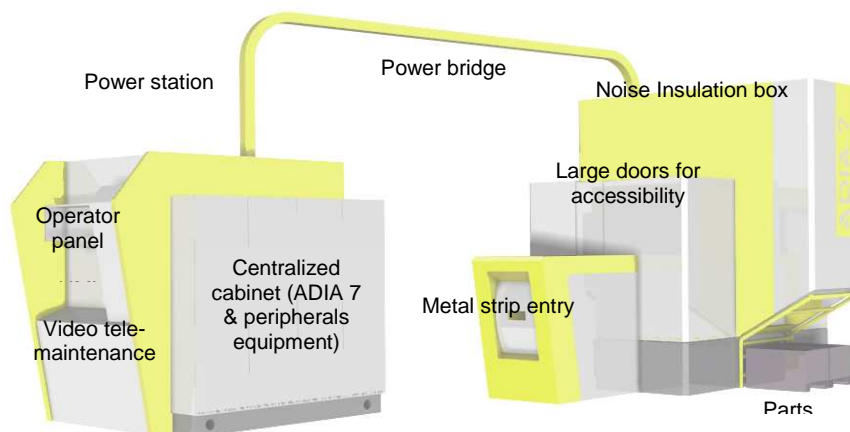

Figure 9: General presentation of ADIA 7.

Safety and working conditions enhancement: Because of the basic principle of the adiabatic phenomena, there is no need of lubricants. This is a direct and economical advantage that also contributes to enhance the working environment.

Due to the generated impacts a special noise insulation box is delivered with the machine. It warrants a noise level under 85 dBA.

The operator panel has been designed to simplify his work. In this purpose, a unique control panel (large tactile screen) is integrated and controls the whole production line (machine + peripheral equipments). Moreover, some cameras are installed into the insulation box so that the operator can see what does happen everywhere from its control panel.

5 Conclusion

The adiabatic blanking process is a new industrial technology. It appears to be a cost efficient solution to answer the demands of the market for sheet metalworking. Indeed, it enables to blank thick materials and to generate functional surfaces with an important potential savings regarding materials, consumables and production costs. ADIAPRESS has developed the process but also the tooling and machines to provide a new solution key in hand in accordance with the current industrial context by taking into account the environment, the working conditions of the user, safety and the maintenance needs, etc. Another known application of the adiabatic process is the cutting of bars and profiles. At the beginning of 2008 ADIAPRESS has also developed the adiabatic cutting process of tubes and hollow profiles. This extra application could be of major interest for different automotive applications like bearings, seats systems, and car body.

Literature

- [1] Pina, V.; *Mesure de temperature des bandes de cisaillement adiabatiques dans alliages de titane. Thèse, Unersity of Paris X- Nanterre, 1997.*
- [2] Maillard, A.; *Découpage adiabatique :Positionnement du procédé. Report CETIM 1L8970, mars 2005.*
- [3] Kräusel, V. ; *High-Speed forming and blanking – An impulse for the ressource-efficient processing of Car Body Components. Car Body Colloquium, Chemnitz, 2008.*